

KNIVES STERILIZER



A/E KS 16



STERILIZZATORE PER COLTELLI A RAGGI UVC

- Armadio per sterilizzazione con supporto interno a rastrelliera, capienza 8-16-32 coltelli
- Sterilizzazione dei coltelli tramite raggi UVC (Luce Ultravioletta, lunghezza d'onda 256 nm)
- Struttura in acciaio inox
- Sportelli in plexiglas fumé con chiusura magnetica
- Lampada UVC da 11 W (mod. KS 8), 15 W (mod. KS 16) e 30 W (mod. KS 32) da sostituire ogni anno
- Spegnimento automatico della lampada all'apertura dello sportello
- Timer
- Conforme al metodo HACCP
- Fissaggio a muro
- Chiusura con chiave su richiesta



UVC STERILISER FOR KNIVES

- Sterilisation cabinet with internal rack, capacity 8-16-32 blades
- Sterilisation of blades using UVC rays (Ultraviolet Light, wave length 256 nm)
- Stainless steel structure
- Smoked Plexiglas doors with magnetic closure
- UVC lamp 11 W (mod. KS 8), 15 W (mod. KS 16) and 30 W (mod. KS 32) to be replaced annually
- Automatic lamp switch-off on opening door
- Timer
- Conforms to HACCP method
- Wall mounted
- Key lock on request



STERILISATEUR POUR COUTEAUX A RAYONS UVC

- Armoire pour la stérilisation avec râtelier interne, capacité 8-16-32 couteaux
- Stérilisation des couteaux par rayons UVC (Lumière ultraviolette, longueur d'onde 256 nm)
- Structure en acier inox
- Portes en plexiglas fumé avec fermeture magnétique
- Lampe UVC de 11 W (mod. KS 8), 15 W (mod. KS 16) et 30 W (mod. KS 32) à remplacer tous les ans
- Extinction automatique de la lampe lors de l'ouverture de la porte
- Minuteur
- Conforme à la méthode HACCP
- Fixage au mur
- Fermeture avec clé sur demande



UVC-STRAHLEN-STERILISIERGERÄT FÜR MESSER

- Sterilisationsschrank mit innerer Abtropfkorbhalterung, Fassungsvermögen 8-16-32 Messer
- Sterilisation der Messer mittels UVC-Strahlen (UV-Licht, Wellenlänge 256 nm)
- Aufbau aus Inox-Stahl
- Türen aus Fumée-Plexiglas mit Magnetverschluss
- UVC-Lampe 11 W (mod. KS 8), 15 W (Mod. KS 16) und 30 W (Mod. KS 32), jährlich auszuwechseln
- Automatische Abschaltung der Lampe beim Öffnen der Tür
- Timer
- In Übereinstimmung mit der HACCP-Methode
- Befestigung an der Wand
- Auf Anfrage Verschluss mit Schlüssel



ESTERILIZADOR DE CUCHILLOS A LUZ ULTRAVIOLETA UVC

- Armario de esterilización con bastidor interno de soporte; capacidad 8-16-32 cuchillos
- Esterilización de los cuchillos con rayos UVC (luz ultravioleta, longitud de onda 256 nm)
- Estructura de acero inoxidable
- Puertas de plexiglas ahumado con cierre magnético
- Lámpara UVC de 11 W (mod. KS 8), 15 W (mod. KS 16) y 30 W (mod. KS 32) a cambiar cada año
- Apagado automático de la lámpara al abrir la puerta
- Temporizador
- Con certificación HACCP
- Fijación de pared
- Cerradura con llave bajo pedido



A/E KS 8



A/E KS 32

CARATTERISTICHE TECNICHE - TECHNICAL SPECIFICATIONS - TECHNISCHE DATEN - CARACTÉRISTIQUES - ESPECIFICACIONES

		A/E KS 8	A/E KS 16	A/E KS 32
Tensione nominale Nominal voltage Tension nominale Nennspannung Tensión nominal	Volt/Hz	230/1/ 50-60	230/1/ 50-60	230/1/ 50-60
Capienza coltelli Blade capacity Capacité couteaux Fassungsvermögen Messer Capacidad cuchillos	n°	8	16	32
Peso netto Net weight Poids net Nettogewicht Peso neto	kg	8	12	20

A/E KS 8

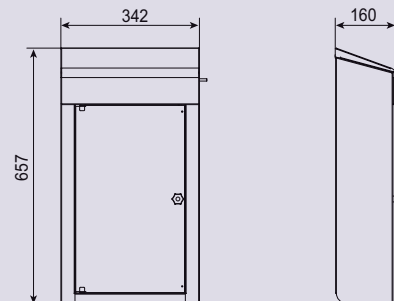

A/E KS 16

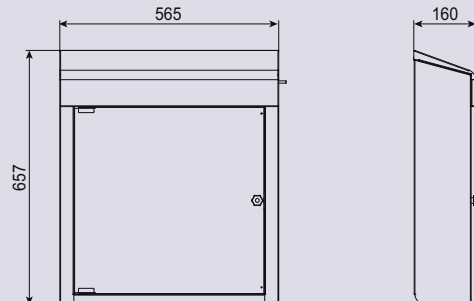

A/E KS 32

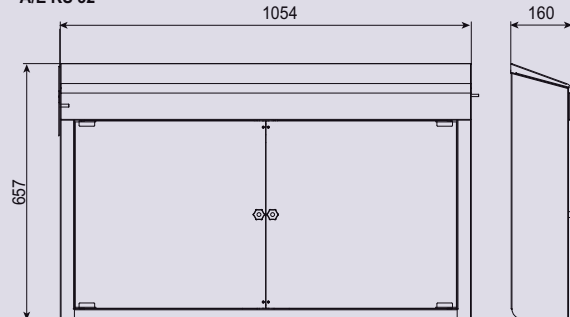

Macchina conforme alle norme CE in materia di igiene e di sicurezza.

The machine complies with CE standards in terms of hygiene and safety.